

LOC		DIST		REVISIONS			
F	LTR	DESCRIPTION	DATE	BY	APPD		
B		REVISED PER 063B-1099-04	22JUNE05	KW	DB		

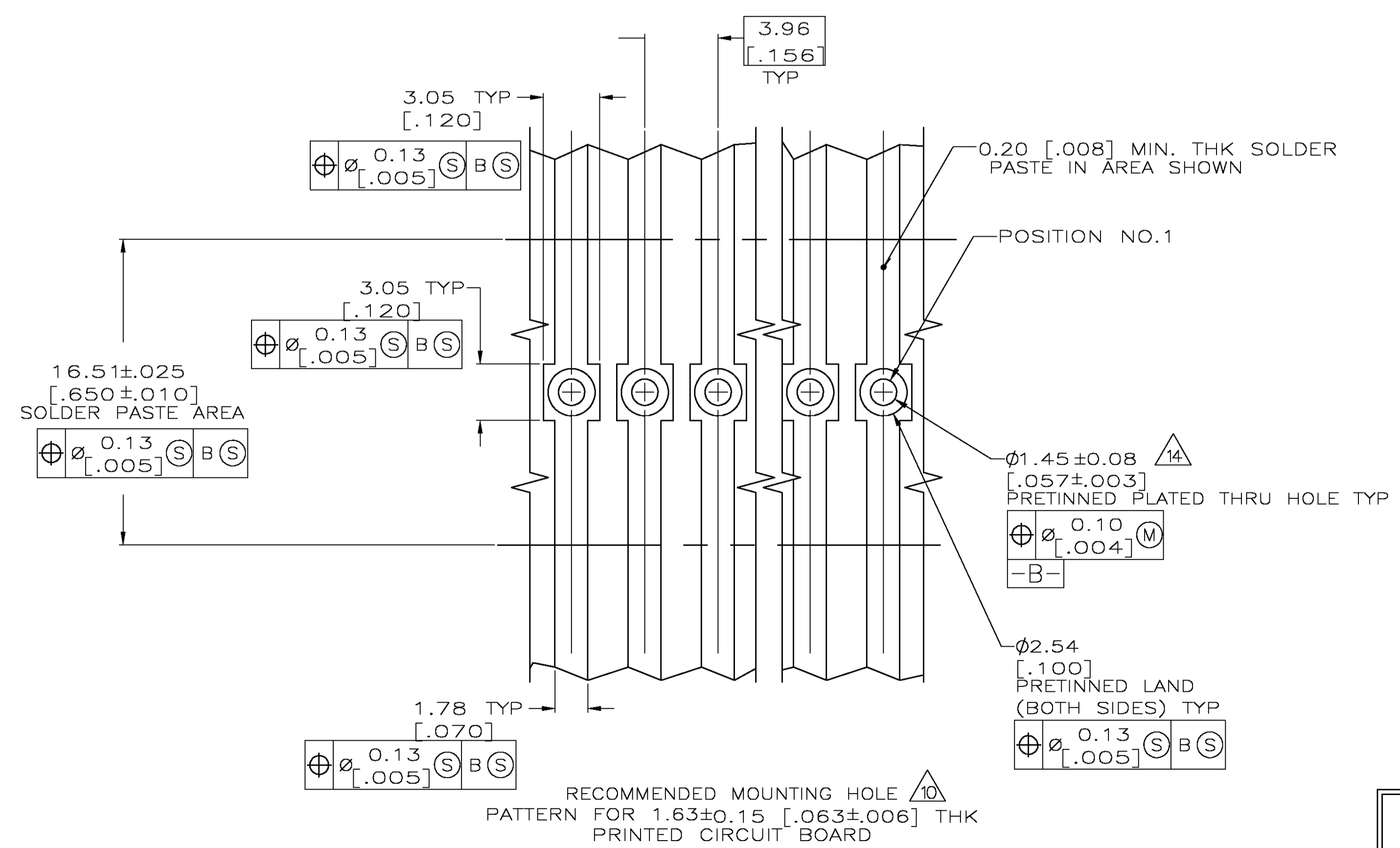

- 1 MATERIAL
HOUSING: POLYAMIDE NYLON,UL94V-O.
POST: COPPER ALLOY
- 2 FINISH
HOUSING: BLACK
POST : SEE NOTES 15 AND 16 FOR PLATING INFORMATION.
- 3 UL MARKING MAY NOT APPEAR ON THE 2 OR 3 POSITION SIZES.
CSA MARKING MAY NOT APPEAR ON THE 2 POSITION SIZE.
- 4 POST SOLDERTAILS COMPLY WITH AMP SOLDERABILITY SPEC 109-11-2.
- 5 POST WITHSTANDS 13.34N [3 LB] MIN AXIAL FORCE IN EITHER DIRECTION WITHOUT DISLODGING.
- 6 APPLIES AT -A-
- 7 APPLIES WHEN THE HEADER IS STRAIGHT.
- 8 PLASTIC PROJECTIONS PERMITTED IN THIS ZONE.
- 9 COORDINATE DIMENSIONS APPLIES FROM THE CENTER OF THE ACTUAL FEATURE.
- 10 DIMENSION APPLY TO COMPONENT SIDE OF BOARD UNLESS OTHERWISE NOTED.
- 11. DIMENSIONS IN BRACKETS ARE IN INCHES.
- 12 ALL POSITION SIZES HAVE THE BACKWALL NOTCHED ON BOTH ENDS AS SHOWN. THE 2 THRU 5 POSITION SIZES HAVE SOLID BACKWALLS. POSITION SIZES 6 AND ABOVE HAVE AN INTERRUPTED BACKWALL AT VARIOUS LOCATIONS (SEE TABLE FOR INTERRUPTION(S) LOCATIONS).
- 13 EDGE OF POLARIZING LOCK WALL TO BE IN LINE WITH CENTERLINE OF ADJACENT POST WITHIN ±0.13 [.005].
- 14 ONE HOLE MAY BE UNDERSIZED (1.17-1.3 [.046-.051]) FOR BOARD RETENTION.
- 15 PLATING: NICKEL UNDERPLATE WITH 0.00038 [.000015] MIN GOLD IN MATING AREA.
- 16 PLATING: NICKEL UNDERPLATE WITH 0.0038 [.00015] MIN THICK OVERPLATE. OVERPLATE IS 93/7 TIN-LEAD FOR -2 THRU -12 & MATTE TIN FOR -32 THRU -42.
- 17. MAXIMUM TEMPERATURE EXPOSURE DURING REFLOW SOLDERING NOT TO EXCEED 280° C (536° F).

POSITION	LENGTH	NO. OF POSITIONS	PART NUMBER
4&5, 8&9	47.42 [1.867]	12	4-647649-2
4&5, 7&8	43.46 [1.711]	11	4-647649-1
3&4, 7&8	39.50 [1.555]	10	4-647649-0
3&4, 6&7	35.53 [1.399]	9	3-647649-9
4&5	31.57 [1.243]	8	3-647649-8
4&5	27.61 [1.087]	7	3-647649-7
3&4	23.65 [.931]	6	3-647649-6
NONE	19.69 [.775]	5	3-647649-5
NONE	15.72 [.619]	4	3-647649-4
NONE	11.76 [.463]	3	3-647649-3
NONE	7.80 [.307]	2	3-647649-2
BACKWALL INTERRUPTION(S) BETWEEN POSTS			
L			
NO. OF POSITIONS			
PART NUMBER			
4&5, 8&9	47.42 [1.867]	12	1-647649-2
4&5, 7&8	43.46 [1.711]	11	1-647649-1
3&4, 7&8	39.50 [1.555]	10	1-647649-0
3&4, 6&7	35.53 [1.399]	9	647649-9
4&5	31.57 [1.243]	8	647649-8
4&5	27.61 [1.087]	7	647649-7
3&4	23.65 [.931]	6	647649-6
NONE	19.69 [.775]	5	647649-5
NONE	15.72 [.619]	4	647649-4
NONE	11.76 [.463]	3	647649-3
NONE	7.80 [.307]	2	647649-2

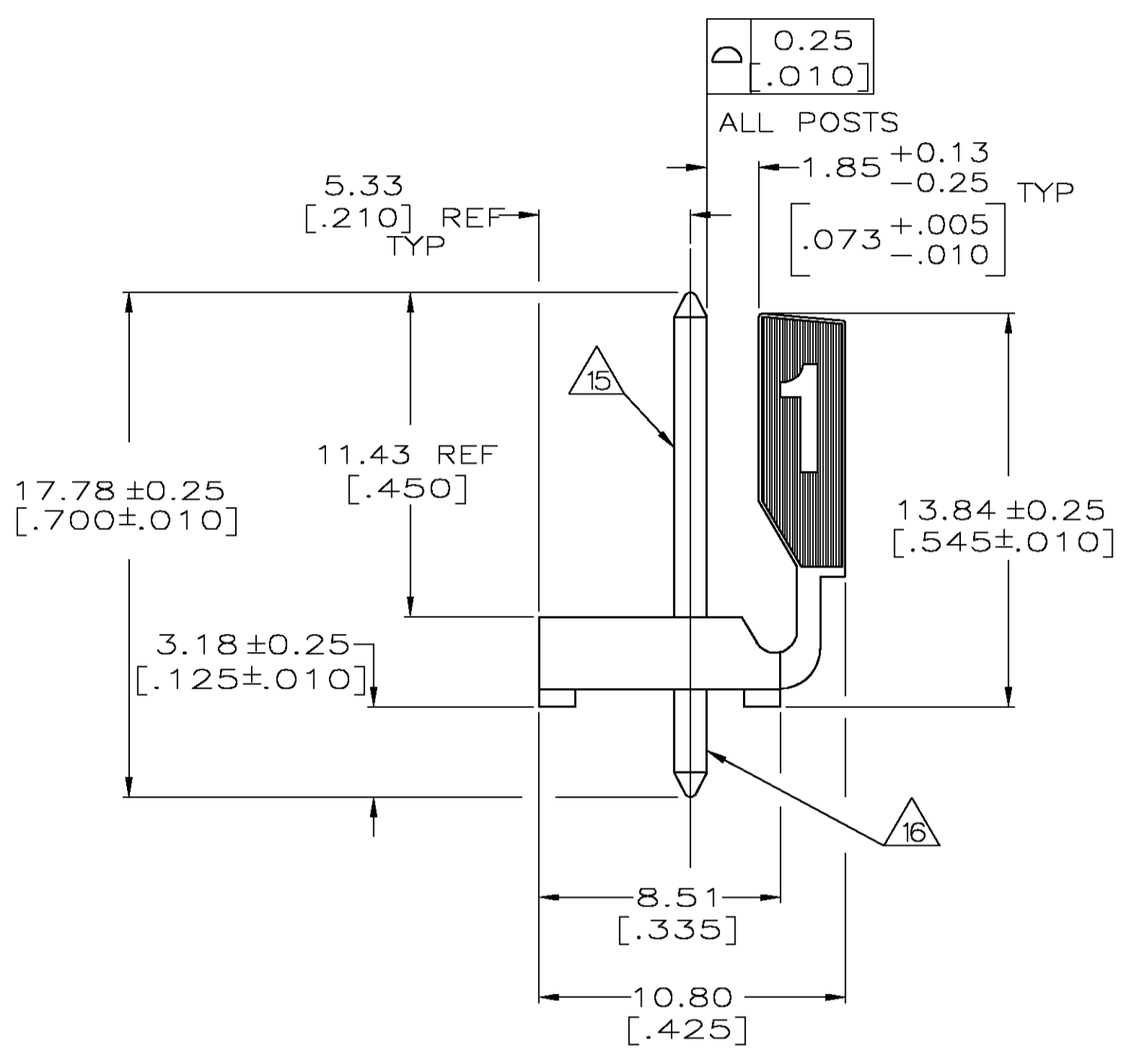
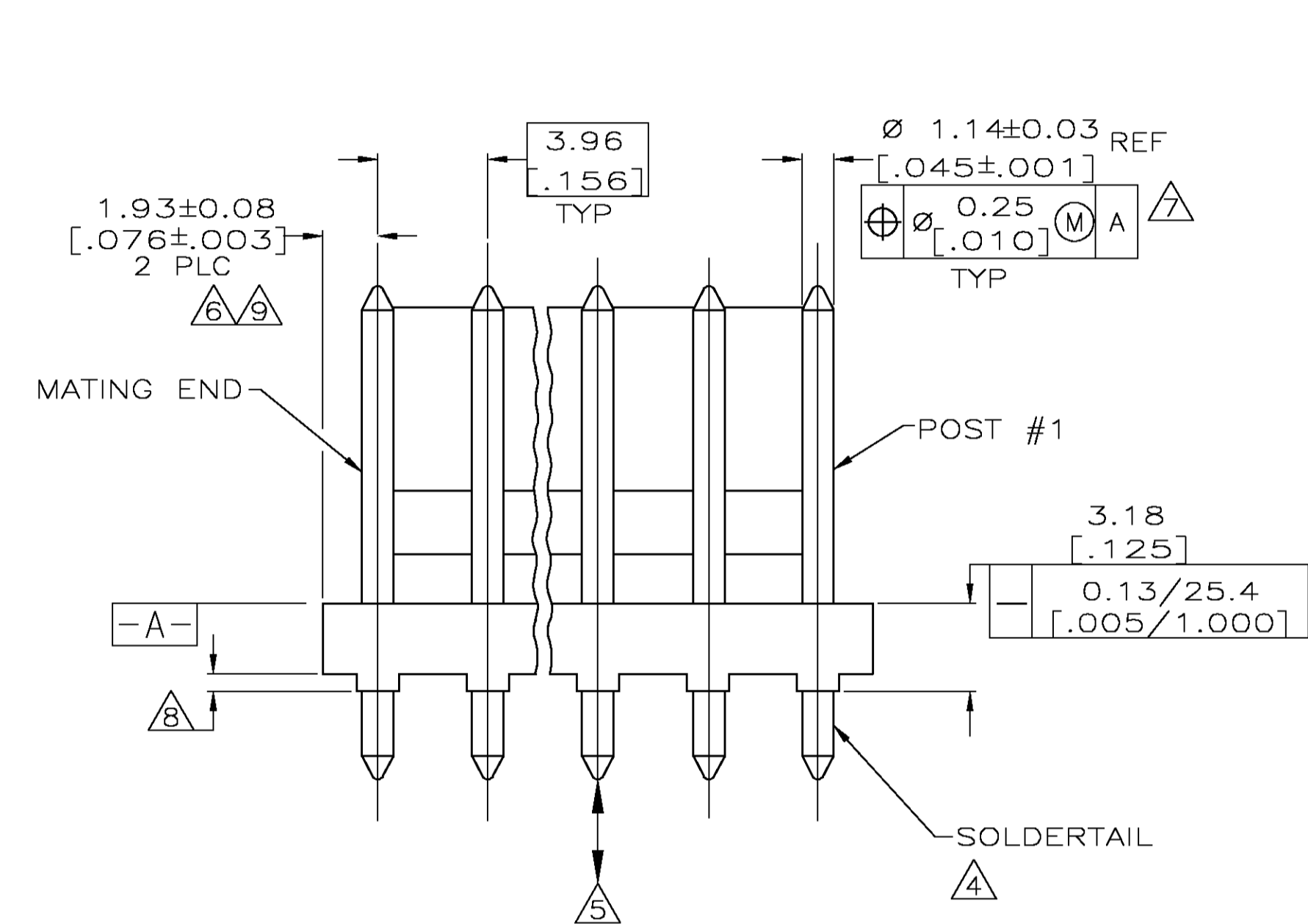
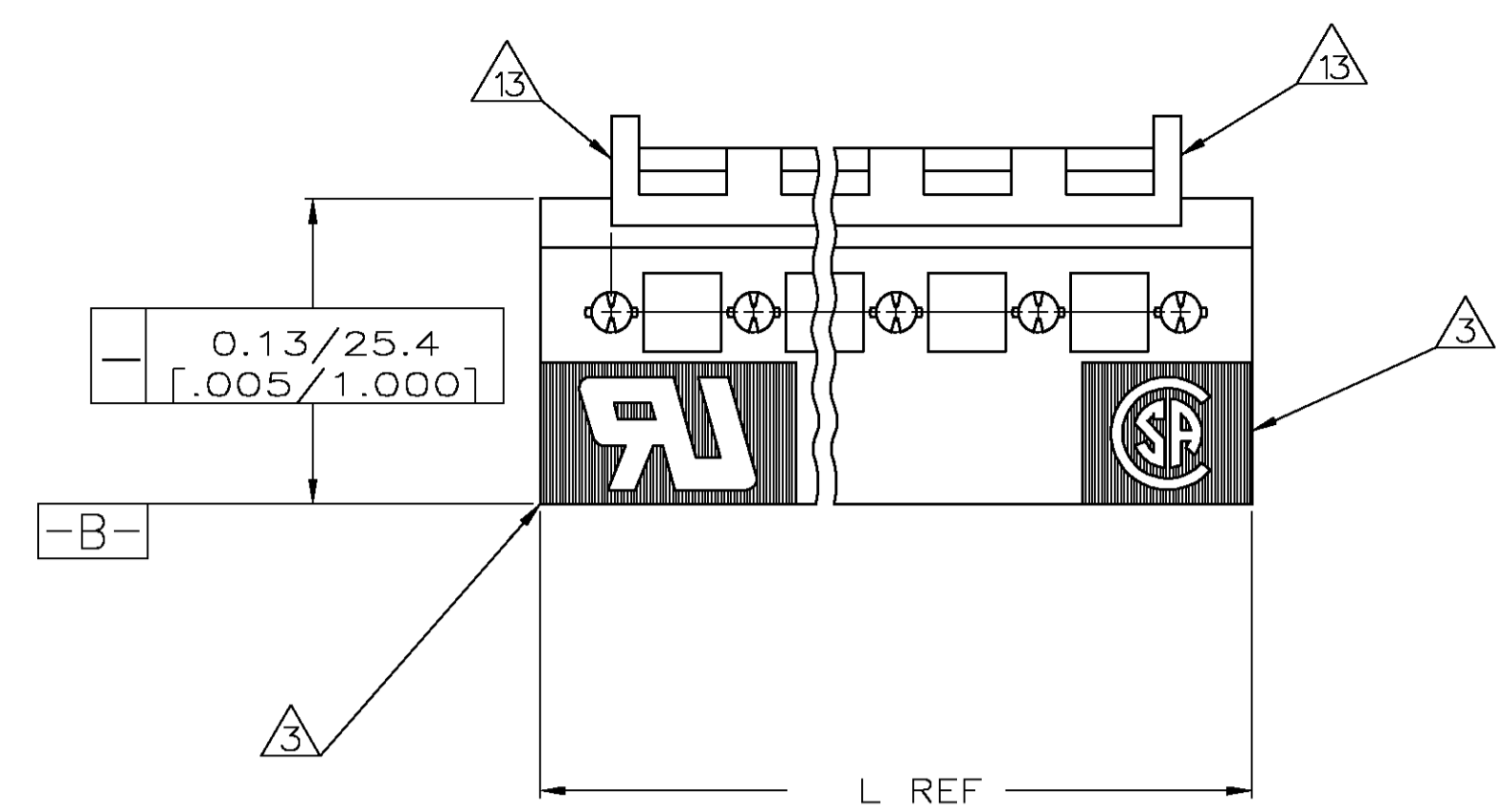
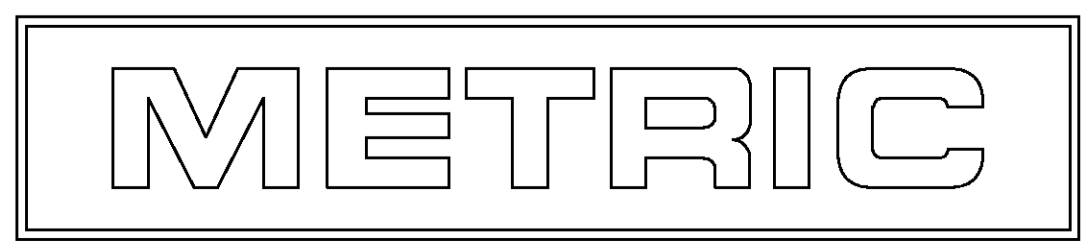

THIS DRAWING IS A CONTROLLED DOCUMENT.

DIMENSIONS: mm [INCHES]	TOLERANCES UNLESS OTHERWISE SPECIFIED:	DRAWING NO.	DATE	REV
0 PLC ± -	1 PLC ± -	23-FEB-04	23-FEB-04	
2 PLC ± 0.13 [.005]	3 PLC ± -			
4 PLC ± -	ANGLES ± -			

MATERIAL: - FINISH: - WEIGHT: -

APPROVED: D. BOSSI
 PRODUCT SPEC: -
 APPLICATION SPEC: -

SIZE: A1
 CASE CODE: -
 DRAWING NO: 00779
 CUSTOMER DRAWING: -

TYCO Electronics
 Tyco Electronics Corporation
 Harrisburg, Pa 17105-3608

MTA-156 ASSEMBLY, HIGH TEMP, STRAIGHT
 .045 ROUND POST, .00015 GOLD PLATED,
 WITHOUT RETENTION PEGS

SCALE: 5:1 SHEET: 1 OF 1 REV: B